

Structural & Design Features:

- Parallel Shaft Two-Stage Gear Reducer
- Induction Hardened Teeth on all Gears and Pinions
- Die Cast Aluminum Housing, Precision Machined for Accurate Shaft Alignment
- Pinions Cut Integral with Shafts
- Ball Bearings on Output Shaft
- Adaptor for Face-Mounting NEMA 56C Motor (with 5/8" Diameter Shaft, 3/16" Keyway)
- Helical Gearing Available for Industrial and Commercial OEM Applications

Output Options:

- Available with 10 Gear Ratios (See Chart Below)



Dimensions and Ratings

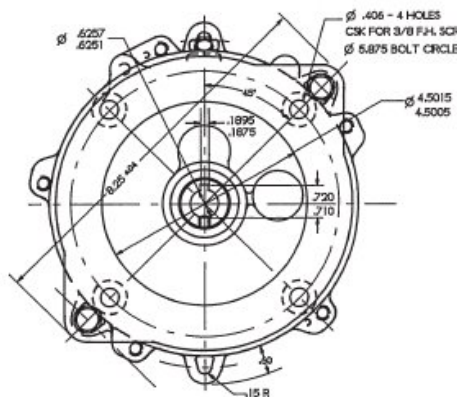

Rear View (Input end)
Mounting Dimensions for NEMA 56C Motor

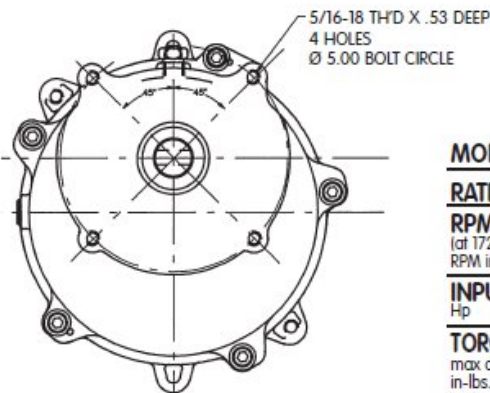
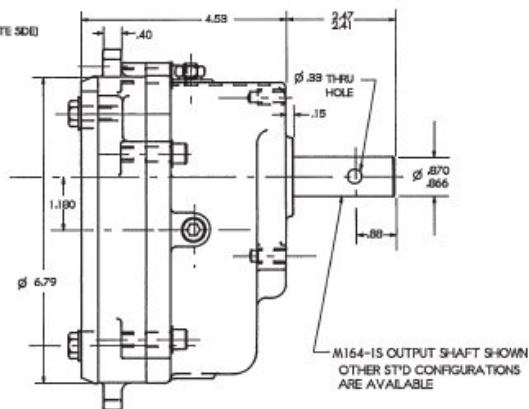

Front View (Output end)

MODEL	M164-X	M164-E	M164-A	M164-L	M164-B	M164-F	M164-K	M164-C	M164-D	M164-G
RATIO	11.08	9.11	7.63	6.48	5.56	4.81	4.18	3.91	3.20	2.63
RPM_{out} (at 1725 RPM _{in})	156	189	226	266	310	358	412	441	539	657
INPUT Hp	0.75	0.90	1.07	1.25	1.48	1.48	1.48	1.48	1.48	1.48
TORQUE max output in-lbs.	290	294	285	290	290	255	231	204	167	140

All data is for an Operating Service Factor of 1 at 1725 RPM input speed (consult Mfr. for allowable overhung loads and for additional output shaft configurations)

